

M116K

11.6" Intel® Core™ i5-7200U Slim Rugged Tablet



KEY FEATURES

- Intel® Core™ i5-7200U Kaby Lake 2.5GHz (Turbo up to 3.1GHz) Slim Rugged Tablet
- Optional Intel® Core™ i5-7300U Kaby Lake 2.60GHz (Turbo up to 3.5GHz)
- 11.6" 1920 x 1080 LED panel with direct optical bonding, tablet industrial windows
- IP65 water and dust proof with MIL-STD-810G rugged housing
- Optional Integrated 1D/2D Barcode Reader and HF RFID for data collection
- Removable battery with hot-swap function for all day productivity

INTRODUCTION

The M116K is a durable and powerful industrial tablet built to withstand tough environments. It ensures reliable performance for professionals in industries such as field service, logistics, and maintenance.

SPECIFICATIONS

Display

Bonding	Optical Bonding for Sunlight Viewability	Resolution	1920x1080
Size	11.6 inches	Contrast Ratio	1000:1
Panel Brightness	850.0 nits	View Angles	85, 85, 85, 85
Type	Projected Capacitive Multi Touch	Viewability	Anti-Glare touch treatment
Touch Mode	Support Hand/Rain, Stylus, Glove Mode		

System Specification

Processor	Intel Core i5-7200U 2.5GHz (up to 3.1GHz) Intel Core i5-7300U 2.6GHz (up to 3.5GHz) (Optional)	Memory	4GB DDR4 SDRAM 8GB DDR4 SDRAM (Optional) 16GB DDR4 SDRAM (Optional)
Storage	128 GB SSD Additional storage available with micro SDXC card slot 256 GB SSD (Optional) 512 GB SSD (Optional)	Security	Trusted Platform Module (TPM) 2.0 Kensington Lock
Operating System	Windows 10 IoT Enterprise (64 bit)	WLAN	Support
BT	Support	WWAN	4G LTE (Optional)
GNSS	GPS, GLONASS	RFID	HF RFID reader 13.56 MHz (Optional)
Sensors	Light sensor/ G-sensor / Gyro		

Camera			
Front Camera	2MP front camera	Rear Camera	8MP rear camera with autofocus and LED light
Mechanical			
Dimension	300.67 x 201.97 x 22.5 mm	Weight	1.5 kg
Cooling System	Fan design		
IO Ports			
USB Port	1 x USB 3.0 (Type A), 1 x USB 3.0 (Type C)	SD Card Slot	1 x Micro SDXC slot
SIM Card Slot	1 x Micro SIM card slot	Video	1 x Micro HDMI (Optional)
Audio	1 x Audio combo 3.5mm audio combo jack Dual Digital Mic With Noise Cancellation	LAN	1 x RJ45-10/100/1000 GigaLAN port (Optional)
Indicator	4x LED Indicator for Power, Battery, HDD, RF status	Docking Connector	1 x 19-pin docking connector
Environment			
Operating Humidity	10% to 90% RH, non-condensing	Operating Temperature	-20°C to 60°C
Storage Temperature	-30°C to 70°C	Shock	MIL-STD-810G Method 516.6 Procedure I
Vibration	MIL-STD-810G Method 514.6 Procedure I	IP rating	IP65
Drop	MIL-STD-810G Method 516.6, 4 ft		
Certification			
Certification	CE, FCC		
Security Function			
SOTI MobiControl	SOTI MobiControl Compliance	Kensington Lock	Kensington Lock Support
Control			
Button	1 x Power, 3 x function keys		
Power			
Battery	Hot-swappable 7.7V typ. 5900 mAh Li-Polymer Battery (2S1P) Optional 7.4V typ. 10280 mAh Li-Polymer Battery (2S2P)	Battery Operating Time	Standard Battery: 8 hours
Power Rating	19V DC	Adapter	100-240V, 50-60Hz (19V DC)
Accessory			
Accessory	Adapter and Power Cord Capacitive Stylus Standard Battery	Optional Accessory	Desk Dock (Optional) Vehicle Dock (Optional) Vehicle Cradle (Optional) Vehicle Charger (Optional) Battery Charger (Optional) High Capacity Battery (Optional) Hand Strap (Optional) VESA Mount Kit (Optional) Shoulder Strap (Optional) Carry Bag (Optional)
Barcode Scanner			
Barcode Scanner	1D/2D barcode reader (Optional)		

DIMENSIONS UNIT:MM

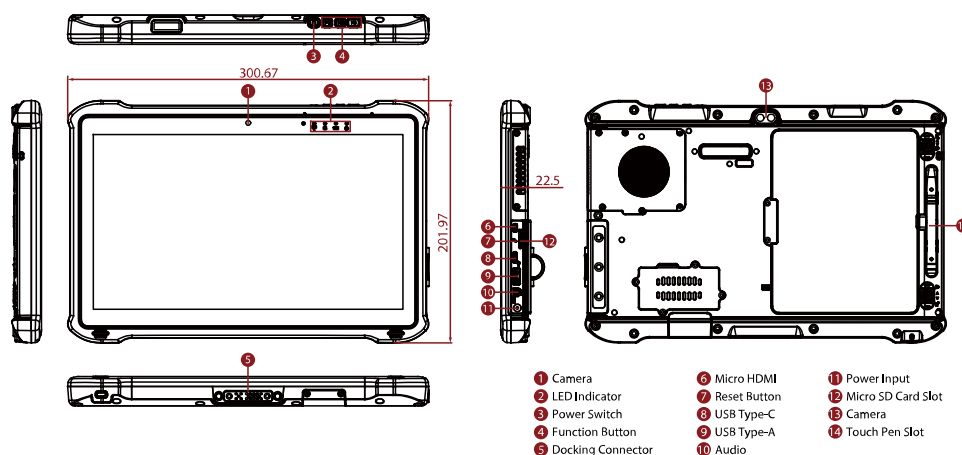

NOTE

- Total usable memory will be less dependent upon actual system configuration.
- The USB Type-C connector follows USB 3.0 standard, which does not support Alternate Mode (ALT) or USB Power Delivery (USB-PD).
- Add-on modules require the expansion port option to be usable.
- TPM 2.0 is available upon request.
- SOTI is available upon request.
- Measured at dimming LCD brightness. Varies depending on the usage conditions, or when an external device is attached.
- Length measurements do not include protrusions. Weight varies with options and active pen.
- The product shown in this datasheet is a standard model. For diagrams that contain customized or optional I/O, please contact the Winmate Sales Team for more information.
- This is a simplified drawing and some components are not marked in detail.